



SEO ITALY





DIREZIONALI DIAMOND
DAFNE
OXFORD
FUTURA
URANIA
IRIS
PRESTIGE
TEKNIK-C
TEKNIK-T
TEKNIK-R
LUXOR
VENUS 2
CALIPSO
SILLA & ATENA

EXECUTIVE TALIA
OLIMPIA
DRIADE
EASY CHAIR
TAYLOR
ORION
GOLF
HERA
COMFORT

OPERATIVE ARIEL
FANTAIL
MIRAGE
NUVOLA
REGAL
SOFIA
ERGOVAR

TECNICHE DISEGNATORE
LABOR PU
LABOR WOOD

CONFERENZA_ATTESA ARIA
UNIVERSAL
CONFERENZA
CONFERENZA PLASTICA + WOOD
CONFERENZA NET + ECO
LUNA
GIMMY & SOLE
VERA & ELENA
DIVANO MAX
DIVANO REX
DIVANO PARIS
DIVANO DUKE

VARIE CARTELLA COLORI
COMPONENTI E ACCESSORI
INFO TECNICHE

S

T

Z

E

T

Z

O

C

SEDITALY

Q U A L I T À

A

I

M

O

N



O

G

R

R

C

E

E R G O N O M Y

E



Q U A L I T Y



Rendi più
confortevole
il tuo luogo
di lavoro

make more
comfortable
your working
place

R C A

P R O J E C T





RICERCA, SVILUPPO

In ufficio cerchiamo organizzazione, intelligenza degli oggetti al servizio della funzione. Chiediamo anche comodità ed ergonomia, perchè il confort è un partner indispensabile nelle lunghe giornate di lavoro. Abbiamo progettato le nostre sedie per uffici direzionali, manageriali, zone operative e sale riunioni ed attesa, declinando colori e stili diversi, con diverse fasce di prezzo e finiture personalizzabili per soddisfare ogni vostra richiesta. Molte sedute sono dotate di certificazione EN 1335, in accordo con la legislazione vigente in termini di ergonomia e sicurezza. Tutte le nostre sedute operative sono costruite nel rispetto delle suddette norme, per offrire sempre e comunque un elevato standard qualitativo e funzionale.

SINERGIE COMMERCIALI

Siamo al vostro fianco per permettervi di essere sempre e comunque concorrenziali. Promozioni su prodotti e quotazioni personalizzate sono gli strumenti al Vostro servizio.

CONTINUITÀ

Riassortimento garantito dei prodotti fuori produzione per almeno 2 anni.

GARANZIA

Tutti i prodotti sono garantiti 2 anni. La garanzia è valida nell'ambito di un utilizzo normale e corretto della sedia e non si applica a quelle parti che sono naturalmente soggette ad usura, dagli imbottiti alle superfici verniciate. Questa garanzia non riconosce alcuna responsabilità o diritto di indennizzo per tutti gli eventuali danni, diretti o indiretti, causati da merce difettosa.

RAPPORTO

Il rapporto commerciale è sempre improntato alla massima trasparenza. Ci avvaliamo della collaborazione di una Compagnia che fornisce tutte le informazioni commerciali e comunica i limiti di credito consigliato. In funzione di queste informazioni, le modalità di pagamento pattuite possono subire variazioni. In particolare: ci riserviamo di chiedere un pagamento garantito. I ritardi di pagamento sono sempre segnalati. I ritardi di pagamento innescano il blocco immediato delle consegne e l'esigibilità di tutti i crediti anche non scaduti.

MIGLIORAMENTO DEI PRODOTTI

Il nostro settore Ricerca e Sviluppo, sia tenendo nel dovuto conto i suggerimenti dei nostri Partners Commerciali, sia seguendo i dettami tecnici delle nuove tecnologie, opera costantemente per migliorare il prodotto. Certi prodotti possono subire, senza preavviso, delle modifiche migliorative rispetto alla loro conformazione iniziale.

RESEARCH, DEVELOPMENT AND CUSTOMIZATION
In the office we look for organization, smart objects at the service of functionality.

We request therefore comfort and ergonomics because those are essential partners during long workdays.

We designed our chair for operative office, managements, operational areas, meeting and waiting room, with multiple color and style customizations and different price bands with personalized finishes available.

Most of the operative chairs come with EN1335 certification in accordance to the ergonomics and safety legislation. All our products are developed in accordance with those rules to offer in all contexts an high quality standard and functionality.

TRADING SYNERGIES

We are on your side to be always competitive. Promoted products and custom quotations are our instruments at your service.

CONTINUITY

Restock guaranteed of all products out of production for 2 years.

GUARANTY

All products have 2 years guaranty. Guaranty is valid with a normal and correct use of chairs and cannot apply to those parts subjected to wear as upholstery or painted parts. This guaranty does not recognize any reasonability or indemnity claims, directly or indirectly, related to defected goods.

RELATIONSHIP

Business relationship is focused on maximum transparency. We are collaborating with a company to provide all commercial information and credit limits recommended. That is the reason why payment methods can be subjected to variations. In particular we reserve to ask a guaranteed payment. Payment delayed will be always reported and it will immediately stop all shipment operations and all invoice's date of collection will be collected even the ones that have not yet fallen due.

PRODUCTS IMPROVEMENT

Our Research & development department is always working on improves our products thanks to the feedbacks of our commercial partners and the new technologies application. Some products can be improved without notice compare to the original configuration.

O R G A N I Z Z A Z I O N E

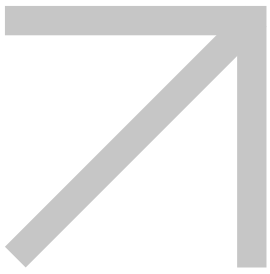

DIAMOND
DAFNE
OXFORD
FUTURA
URANIA
IRIS
PRESTIGE
TEKNIK-C
TEKNIK-T
TEKNIK-R
LUXOR
VENUS 2
CALIPSO
SILLA & ATENA

FUNZIONALI E DI CLASSE

FIRST CLASS FUNCTIONAL



Oggetti preziosi, forme, ispirazioni,
nuove idee che sanno raccontare
momenti importanti della nostra vita.
Una collezione dal design innovativo, ricercato,
deciso: oggetti che spiccano tra gli altri
e ci accompagnano nel tempo con l'energia
della loro personalità.
Le nuove linee Direzionali presentano
poltrone importanti per chi ama distinguersi.
Giochi di forme, colori e materiali
sono al centro di una ricerca che unisce
tecnologia, fantasia ed eleganza.

Precious objects, lines, inspirations,
new ideas to narrate the most important moments of our life.
A collection with an innovative design, refined, determined:
they stand out and drive us over time with
the energy of the personality.
The new Managements lines show armchairs
for people the love distinguish themselves.
Different shapes, colors and materials are the center
that joins together technology, fantasy and elegance.



DIREZIONALI

MANAGER

DIAMOND CR

PRODUCT AND DESIGN

MADE IN ITALY



DIAMOND_CR ALTA



8



DIAMOND_CR ALTA



DIAMOND_CR MEDIA



DIAMOND_CR SLITTA



DIAMOND_CR MEDIA



DIAMOND_CR SLITTA



	A	H	h	h	kg	☐	n	m ³
ALTA	63	65	45/57	115/127	22	67X44X88	1	0,26
MEDIA	63	65	45/57	100/112	18	67X44X88	1	0,26
SLITTA	61	68	49	88	19	90x48x68	1	0,294

D I A M O N D

P R O D U C T A N D D E S I G N

M A D E I N I T A L Y



DIAMOND_CR ALTA



10



DIAMOND_ALTA



DIAMOND_MEDIA



DIAMOND_SLITTA



DIAMOND_ALTA



DIAMOND_ALTA



DIAMOND_MEDIA



DIAMOND_MEDIA

	A	H	h	h	kg		n	m ³
ALTA	63	65	45/57	115/127	22	67X44X88	1	0,26
MEDIA	63	65	45/57	100/112	18	67X44X88	1	0,26
SLITTA	61	68	49	88	19	90x48x68	1	0,294

DAFNE

PRODUCT AND DESIGN

MADE IN ITALY



DAFNE_CR ALTA

12



DAFNE_CR ALTA



DAFNE_CR MEDIA



DAFNE_CR SLITTA



DAFNE_ALTA



DAFNE_CR MEDIA



DAFNE_MEDIA



DAFNE_CR SLITTA



DAFNE_ALTA



DAFNE_MEDIA



DAFNE_SLITTA

							n	m ³
ALTA	63	65	45/57	115/127	22	67X44X88	1	0,26
MEDIA	63	65	45/57	100/112	18	67X44X88	1	0,26
SLITTA	63	65	47	97	18	90x48x68	1	0,294

O X F O R D



P R O D U C T A N D D E S I G N

M A D E I N I T A L Y



OXFORD ALTA_SYNCRO

14



OXFORD ALTA_SYNCRO



OXFORD MEDIA_SYNCRO



OXFORD MEDIA_VISITATORE



OXFORD ALTA_SYNCRO



OXFORD ALTA_SYNCRO



OXFORD MEDIA_SYNCRO



OXFORD MEDIA_VISITATORE

							n	m ³
ALTA	63	65	43/55	108/120	23	67X44X88	1	0,26
MEDIA	63	65	43/55	90/102	19	67X44X88	1	0,26
VISITATORE	63	65	42/54	93/105	14	60x40x65	1	0,16

FUTURA



PRODUCT AND DESIGN

M A D E I N I T A L Y



FUTURA_ALTA

16



FUTURA_ALTA



FUTURA_MEDIA



FUTURA_ALTA



FUTURA_ALTA









FUTURA_MEDIA



FUTURA_MEDIA



							n	m ³
ALTA	65	69	43/54	117/137	23	88x47x69	1	0,29
MEDIA	65	69	43/54	97/116	21	88x47x69	1	0,29

U R A N I A

P R O D U C T A N D D E S I G N

M A D E I N I T A L Y



URANIA_ALTA

18



URANIA_ALTA



URANIA_MEDIA



URANIA_ALTA









URANIA_ALTA



URANIA_MEDIA



URANIA_MEDIA

							n	m ³
ALTA	65	65	43/53	117/127	23	A "L"	1	0,26
MEDIA	63	65	43/53	89/99	21	73X63X43	1	0,19

I R I S



PRODUCT AND DESIGN

M A D E I N I T A L Y



IRIS ALTA_SYNCRO



20



IRIS ALTA_SYNCRO



IRIS MEDIA_SYNCRO



IRIS MEDIA_SLITTA



IRIS MEDIA_SYNCRO



IRIS MEDIA_SYNCRO



IRIS MEDIA_SLITTA



	A	H	h	h	kg		n	m ³
ALTA	63	65	43/55	108/120	20	67X44X88	1	0,26
MEDIA	63	65	43/55	90/102	18	67X44X88	1	0,26
SLITTA	51	58	47	100	15	54X64X74	1	0,25

P R E S T I G E

P R O D U C T A N D D E S I G N

M A D E I N I T A L Y



PRESTIGE ALTA_SYNCRO



PRESTIGE ALTA_SYNCRO



PRESTIGE MEDIA_SYNCRO



PRESTIGE BASSA_FISSA



PRESTIGE MEDIA_SYNCRO



PRESTIGE BASSA_FISSA



PRESTIGE BASSA_4 GAMBE



PRESTIGE BASSA_SLITTA



PRESTIGE BASSA_4 GAMBE



PRESTIGE BASSA_SLITTA

	A	H	h	h	kg	☐	n	m ³
ALTA	64	66	43/55	115/127	18	67X44X88	1	0,26
MEDIA	64	66	43/55	97/109	16	60X40X65	1	0,16
BASSA	62	64	43/55	85/97	9	60X40X65	1	0,16
4 GAMBE	50	62	47	86	9	54X64X74	2	0,25
SLITTA	48	58	47	87	10	54X64X74	2	0,25

T E K N I K C

PRODUCT AND DESIGN

M A D E I N I T A L Y



TEKNIK C_ALTA

24



TEKNIK C_ALTA



TEKNIK C_MEDIA



TEKNIK C_SLITTA



TEKNIK C_ALTA



TEKNIK C_MEDIA



TEKNIK C_SLITTA

	A	H	h	h	kg		n	m ³
ALTA	58	68	42/52	106/116	22	67X44X88	1	0,26
MEDIA	58	68	42/52	88/98	20	67X44X88	1	0,26
SLITTA	56	62	47	89	12	58X64X90	1	0,34

T E K N I K T

PRODUCT AND DESIGN

M A D E I N I T A L Y



TEKNIK T_ALTA

26



TEKNIK T_ALTA



TEKNIK T_MEDIA



TEKNIK T_SLITTA



TEKNIK T_MEDIA



TEKNIK T_SLITTA



	A	H	h	h	kg		n	m ³
ALTA	58	68	42/52	106/116	21	67X44X88	1	0,26
MEDIA	58	68	42/52	88/98	19	67X44X88	1	0,26
SLITTA	56	62	46	89	11	58X64X90	1	0,34

T E K N I K R

P R O D U C T A N D D E S I G N

M A D E I N I T A L Y



TEKNIK R_ALTA

28



TEKNIK R_ALTA



TEKNIK R_MEDIA



TEKNIK R_SLITTA



TEKNIK R_MEDIA



TEKNIK R_SLITTA

							n	m ³
ALTA	58	68	42/52	106/116	20	67X44X88	1	0,26
MEDIA	58	68	42/52	88/98	18	67X44X88	1	0,26
SLITTA	56	62	45	89	10	58X64X90	1	0,34

LUXOR

PRODUCT AND DESIGN

M A D E I N I T A L Y



30



LUXUR T_ALTA



LUXUR T_ALTA



LUXUR T_MEDIA



LUXUR T_SLITTA



LUXUR T_ALTA



LUXUR R_ALTA



LUXUR T_MEDIA



LUXUR R_MEDIA



LUXUR R_ALTA



LUXUR R_MEDIA



LUXUR R_SLITTA

	A	H	h	h	kg	Box	n	m ³
ALTA	57	65	44/55	108	20	67X44X88	1	0,26
MEDIA	57	65	44/55	91	18	67X44X88	1	0,26
SLITTA	57	63	46	91	11	58X64X90	1	0,34

VENUS 2

PRODUCT AND DESIGN

M A D E I N I T A L Y



VENUS 2_CR ALTA

32



VENUS 2_CR ALTA



VENUS 2_CR MEDIA



VENUS 2_CR SLITTA



VENUS 2_CR MEDIA



VENUS 2_MEDIA



VENUS 2_CR SLITTA



VENUS 2_SLITTA



VENUS 2_ALTA



VENUS 2_MEDIA



VENUS 2_SLITTA

	Altura schienale	Altura sedile	Profondità sedile	Profondità schienale	Peso	Dimensioni imballaggio	Quantità	Volume
	Alt	H	h	H	kg	Imb	n	m ³
ALTA	68	75	46/56	115	25	101X45X72	1	0,33
MEDIA	68	75	46/56	95	23	88X43X70	1	0,27
SLITTA	68	75	46	93	19	88X43X70	1	0,27

CALIPSO

PRODUCT AND DESIGN

M A D E I N I T A L Y



CALIPSO_ALTA

34



CALIPSO_ALTA



CALIPSO_MEDIA



CALIPSO_SLITTA









CALIPSO_MEDIA



CALIPSO_SLITTA



							n	m ³
ALTA	64	70	49/58	109	16	75X65X32	1	0,16
MEDIA	64	70	49/58	98	14	75X65X32	1	0,16
SLITTA	64	63	48	98	14	89X48X66	1	0,28

SILLA & ATENA

PRODUCT AND DESIGN

MADE IN ITALY



ATENA_SLITTA

36



SILLA_SLITTA



ATENA_SLITTA



SILLA_SLITTA



ATENA_SLITTA



							n	m ³
SILLA	57	56	46	82	6	102X53X63	2	0,34
ATENA	57	64	46	83	7	102X58X63	2	0,34

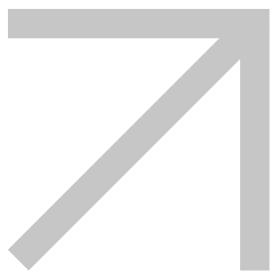

TALIA
OLIMPIA
DRIADE
EASY CHAIR
TAYLOR
ORION
GOLF
HERA
COMFORT

UNA NUOVA DIMENSIONE
A NEW DIMENSION



Il prestigio, l'eleganza, il comfort, la tecnologia; li abbiamo raccolti in una gamma completa di sedute realizzate con stili, materiali, finiture e dettagli che si adattano a gusti diversi, attraversando differenti fasce di prezzo. A voi lasciamo inventare le giuste collocazioni, giocare con contesti e mescolare materiali innovativi e classici, trovando infinite ispirazioni per narrare le mille storie del vivere umano.

Distinction, elegance, comfort, technology have been collected inside a collection with styles, materials, finishing and details that fits different tastes and price bands. We leave you the freedom to create the best placement, play with contexts and mix innovative materials with traditional ones, finding never-ending inspiration to narrate the thousand stories of people living.



EXECUTIVE
EXECUTIVE

TALIA



PRODUCT AND DESIGN

MADE IN ITALY



TALIA_SY PGT



40

Sedile e schienale in rete
Mesh seat and back





TALIA_SY PGT



TALIA_SY PGT



TALIA_SY



TALIA_SY



TALIA_SY PGT



TALIA_SY

	A	H	h	h	kg	Box	n	m ³
SY PGT	67	62	43/53	118	21	67X67X44	1	0,20
SY	67	62	43/53	100	20	67X67X44	1	0,20

OLIMPIA



PRODUCT AND DESIGN

M A D E I N I T A L Y



OLIMPIA_SY PGT



OLIMPIA_SY PGT



OLIMPIA_SY



OLIMPIA_SY PGT



OLIMPIA_SY PGT



OLIMPIA_SY



OLIMPIA_SY

	A	H	h	h	kg		n	m ³
SY PGT	66	62	42/55	116	16	60X40X65	1	0,16
SY	66	62	42/55	98	15	60X40X65	1	0,16

D R I A D E



PRODUCT AND DESIGN

M A D E I N I T A L Y



DRIADE_SY CR PGT04



DRIADE_SY PGT04



DRIADE_SY



DRIADE_SY PGT04



DRIADE_SY



DRIADE_SY CR

							n	m ³
SY PGT04	50	48	42/53	120	19	60X40X65	1	0,16
SY	50	48	42/53	95	18	60X40X65	1	0,16

EASY CHAIR

PRODUCT AND DESIGN

MADE IN ITALY



EASY_SY PGT04

46



EASY_SY PGT04



EASY_SY



EASY_SLITTA



EASY_SY PGT04



EASY_SY



EASY_SLITTA

							n	m ³
SY PGT04	50	48	42/53	115	18	60X40X65	1	0,16
SY	50	48	42/53	93	17	60X40X65	1	0,16
SLITTA	50	48	46	99	14	55X65X75	2	0,27

TAYLOR



PRODUCT AND DESIGN

M A D E I N I T A L Y



TAYLOR_SY PGT04



48



TAYLOR_SY PGT04



TAYLOR_SY CR



TAYLOR_CPL PGT04



TAYLOR_CR CPL



TAYLOR_SY



TAYLOR_SY



TAYLOR_CR CPL



TAYLOR_CR SLITTA



TAYLOR_SLITTA

	A	H	h	h	kg		n	m ³
SY PGT04	50	48	42/53	120	21	60X40X65	1	0,16
SY	50	48	42/53	105	20	60X40X65	1	0,16
CPL PGT04	50	48	42/53	120	18	60X40X65	1	0,16
CPL	50	48	42/53	105	17	60X40X65	1	0,16
SLITTA	50	48	46	100	14	55X65X75	2	0,27

O R I O N



P R O D U C T A N D D E S I G N

M A D E I N I T A L Y



ORION_SY PGT02



50



ORION_SY PGT02



ORION_SY



ORION_CPL PGT02



ORION_CPL



ORION_CPL PGT02



ORION_CPL



ORION VISITATORE _4G



ORION VISITATORE _SLITTA



ORION VISITATORE _4G



ORION VISITATORE _SLITTA

	A	H	h	h	kg		n	m ³
SY PGT02	50	48	42/53	118	19	60X40X65	1	0,16
SY	50	48	42/53	102	18	60X40X65	1	0,16
CPL PGT02	50	48	42/53	118	17	60X40X65	1	0,16
CPL	50	48	42/53	102	16	60X40X65	1	0,16
4G	50	48	46	97	14	55X65X75	2	0,27
SLITTA	50	48	46	97	14	55X65X75	2	0,27

G O L F



PRODUCT AND DESIGN

M A D E I N I T A L Y



GOLF_SY PGT04



52



GOLF_SY PGT04



GOLF_SY ALTA



GOLF_SY BASSA



GOLF_CPL ALTA



GOLF_CPL BASSA



GOLF_CPL ALTA



GOLF_SY BASSA



GOLF_4G



GOLF_SLITTA



GOLF_4G



GOLF_SLITTA

	Altura schienale	Altura schienale (senza braccioli)	Altezza sedile	Altezza schienale	Peso	Dimensioni imballaggio	n	m ³
SY PGT04	50	48	42/53	115	19	60X40X65	1	0,16
SY ALTA	50	48	42/53	105	18	60X40X65	1	0,16
SY BASSA	50	48	42/53	93	17	60X40X65	1	0,16
CPL ALTA	50	48	42/53	105	17	60X40X65	1	0,16
CPL BASSA	50	48	42/53	93	16	60X40X65	1	0,16
4G	50	48	46	101	14	55X65X75	2	0,27
SLITTA	50	48	46	101	14	55X65X75	2	0,27

HERA



PRODUCT AND DESIGN

MADE IN ITALY



HERA_SY PGT01



54



HERA_SY PGT01



HERA_SY



HERA_CPL PGT01



HERA_CPL



HERA_SY



HERA_CPL



HERA_4G



HERA_SLITTA



HERA_4G



HERA_SLITTA

	A	H	h	h	kg	Box	n	m ³
SY PGT01	50	45	43/55	116	19	60X40X65	1	0,16
SY	50	45	43/55	98	18	60X40X65	1	0,16
CPL PGT01	50	45	43/55	116	17	60X40X65	1	0,16
CPL	50	45	43/55	98	16	60X40X65	1	0,16
4G	47	44	45	95	12	55X65X75	2	0,27
SLITTA	47	44	45	95	12	55X65X75	2	0,27

C O M F O R T



P R O D U C T A N D D E S I G N

M A D E I N I T A L Y



COMFORT_SY PGT01



56



COMFORT_SY PGT01



COMFORT_SY



COMFORT_CPL PGT01



COMFORT_CPL



COMFORT_CPL PGT01



COMFORT_SY PGT01



COMFORT_4G



COMFORT_SLITTA



COMFORT_4G



COMFORT_SLITTA

	A	H	h	h	kg	Box	n	m ³
SY PGT01	50	48	42/53	118	19	60X40X65	1	0,16
SY	50	48	42/53	102	18	60X40X65	1	0,16
CPL PGT01	50	48	42/53	118	17	60X40X65	1	0,16
CPL	50	48	42/53	102	16	60X40X65	1	0,16
4G	50	48	46	97	14	55X65X75	2	0,27
SLITTA	50	48	46	97	14	55X65X75	2	0,27

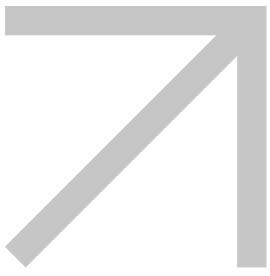

ARIEL
FANTAIL
MIRAGE
NUVOLA
REGAL
SOFIA
ERGOVAR

DESIGN E QUALITÀ DEI MATERIALI
DESIGN AND QUALITY



Sediamoci e costruiamo la nostra vita.
Da sempre, gli esseri umani quando decidono
di narrare, comunicare, scambiare storie ed opinioni,
per evolversi nella ricerca del loro futuro, si siedono vicini.
La sedia è il luogo dei pensieri, delle meditazioni,
delle idee, dei racconti e dei confronti.
Bisogna sentirsi bene seduti.
Ecco perché abbiamo raccolto una gamma
completa di sedute operative con stili accattivanti,
sicure e certificate che vi accompagnano
nel vostro vivere quotidiano.

Let's sit and start build our life.
As far back human beings sit together to narrate,
communicate, exchange views and opinions,
evolve in a pursuit of their future.
To this end we have collected a complete selection
of operative chairs with fascinating styles,
safe and certificated that drive us into our everyday life.



OPERATIVE
OPERATIVE

ARIEL



PRODUCT AND DESIGN

MADE IN ITALY



ARIEL_ALTA SY



60



ARIEL_ALTA SY



ARIEL_MEDIA SY



ARIEL_ALTA CPL



ARIEL_MEDIA CPL



ARIEL_BASSA CPL



ARIEL_MEDIA CPL



ARIEL_MEDIA CPL



ARIEL_BASSA CPL



ARIEL_BASSA CPL



ARIEL_4G



ARIEL_SLITTA

	A	H	h	h	kg		n	m ³
ALTA	64	64	42/54	107	15	61X35X61	1	0,13
MEDIA	64	64	42/54	99	14	61X35X61	1	0,13
BASSA	64	64	42/54	92	13	61X35X61	1	0,13
4G	50	61	46	90	11	54X64X74	2	0,26
SLITTA	48	60	46	90	11	54X64X74	2	0,26

FANTAIL



PRODUCT AND DESIGN

MADE IN ITALY



FANTAIL_SY



FANTAIL_SY



FANTAIL_CPM



FANTAIL_CPM



FANTAIL_CPM



FANTAIL_4G



FANTAIL_SLITTA



FANTAIL_4G



FANTAIL_SLITTA

	A	H	h	h	kg		n	m ³
SY/CPM	64	64	42/54	94	14	61X35X61	1	0,13
4G	50	61	46	96	11	54X64X74	2	0,26
SLITTA	48	60	46	96	11	54X64X74	2	0,26

M I R A G E



P R O D U C T A N D D E S I G N

M A D E I N I T A L Y



MIRAGE_SY



MIRAGE_SY



MIRAGE_CPM



MIRAGE_CPM



MIRAGE_CPM



MIRAGE_4G



MIRAGE_SLITTA



MIRAGE_4G



MIRAGE_SLITTA

							n	m ³
SY/CPM	64	64	42/54	94	14	61X35X61	1	0,13
4G	50	61	46	96	11	54X64X74	2	0,26
SLITTA	48	60	46	96	11	54X64X74	2	0,26

NUVOLA



PRODUCT AND DESIGN

MADE IN ITALY



NUVOLA_SY



NUVOLA_SY



NUVOLA_CPM



NUVOLA_CPM



NUVOLA_CPM



NUVOLA_4G



NUVOLA_SLITTA



NUVOLA_4G



NUVOLA_SLITTA

	A	H	h	h	kg		n	m ³
SY/CPM	64	64	42/54	94	14	61X35X61	1	0,13
4G	50	61	46	96	11	54X64X74	2	0,26
SLITTA	48	60	46	96	11	54X64X74	2	0,26

R E G A L



P R O D U C T A N D D E S I G N

M A D E I N I T A L Y



REGAL_ALTA SY



REGAL_ALTA SY



REGAL_ALTA CPM



REGAL_BASSA CPM



REGAL_ALTA CPM



REGAL_BASSA CPM



REGAL_4G



REGAL_SLITTA



REGAL_4G



REGAL_SLITTA

	A	H	h	h	kg	Box	n	m ³
ALTA	64	64	42/54	99	12	61X35X61	1	0,13
BASSA	64	64	42/54	92	10	61X35X61	1	0,13
4G	50	61	46	88	11	54X64X74	2	0,26
SLITTA	48	60	46	88	11	54X64X74	2	0,26

SOFIA



P R O D U C T A N D D E S I G N

M A D E I N I T A L Y



SOFIA_ALTA CPM

70



SOFIA_ALTA CPM



SOFIA_BASSA CPM



SOFIA_BASSA CPM



SOFIA_BASSA CPM



SOFIA_4G



SOFIA_SLITTA



SOFIA_4G



SOFIA_SLITTA

	A	H	h	h	kg	☐	n	m ³
ALTA	62	62	43/55	98	9	57X26X57	1	0,085
BASSA	62	62	43/55	86	7	57X26X57	1	0,085
4G	50	61	46	86	6	54X64X74	2	0,26
SLITTA	48	60	46	86	6	54X64X74	2	0,26

ERGOVAR



PRODUCT AND DESIGN

MADE IN ITALY



ERGOVAR_CPM



ERGOVAR_CPM



ERGOVAR_CPM



ERGOVAR_CPM



ERGOVAR_4G



ERGOVAR_SLITTA



ERGOVAR_4G



ERGOVAR_SLITTA

	A	H	h	h	kg		n	m ³
CPM	62	62	43/55	92	8	57X26X57	1	0,085
4G	50	61	46	90	7	54X64X74	2	0,26
SLITTA	48	60	46	90	7	54X64X74	2	0,26

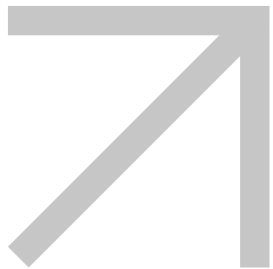

DISEGNATORE
LABOR PU
LABOR WOOD

TECNOLOGIA CALIBRATA

MASSIVE TECHNOLOGY



Atmosfere antiche,
una lama che seziona il legno
spargendo nell'aria
profumo di segatura e sudore.

Antique atmosphere,
a blade that divide the wood spreading
aroma in sweat in the air.



TECNICHE
TECHNICS

DISEGNATORE

PRODUCT AND DESIGN

MADE IN ITALY



SOFIA_BASSA DISEGNATORE



SOFIA_BASSA DISEGNATORE



ARIEL_BASSA DISEGNATORE



ERGOVAR_DISEGNATORE



SOFIA_BASSA DISEGNATORE



ERGOVAR_DISEGNATORE



ARIEL_BASSA DISEGNATORE

	A	H	h	h	kg	☐	n	m ³
SOFIA BASSA DIS	62	62	56/82	98	12	61X61X30	1	0,115
ERGOVAR DIS	62	62	56/82	105	13	61X61X30	1	0,115
ARIEL BASSA DIS	64	64	56/82	106	15	61X61X30	1	0,115

L A B O R P U

P R O D U C T A N D D E S I G N

M A D E I N I T A L Y



LABOR_PU DISEGNATORE



LABOR_PU DISEGNATORE



LABOR_PU CPM



LABOR_PU CPM



LABOR_45 PU



LABOR_60 PU



LABOR_60 PU



LABOR_45 PU

	A	H	h	h	kg		n	m ³
LABOR PU CPM	64	64	43/56	90	11	61X61X30	1	0,13
LABOR PU DISEGN	64	64	58/84	106	15	61X61X30	1	0,13
LABOR 45 PU	58	58	43/56	****	6	57X26X57	1	0,082
LABOR 60 PU	58	58	58/84	****	10	57X26X57	1	0,082

LABOR WOOD

PRODUCT AND DESIGN

MADE IN ITALY



80



LABOR WOOD_DISEGNATORE



LABOR WOOD_DISEGNATORE



LABOR WOOD_FISSA



LABOR WOOD_FISSA



LABOR_60 WOOD



LABOR_45 WOOD



LABOR_60 WOOD



LABOR_45 WOOD

	A	H	h	h	kg	Box	n	m ³
LABOR W FISSA	58	58	43/56	89	8	57X26X57	1	0,082
LABOR W DISEGN	58	58	58/84	105	12	57X26X57	1	0,082
LABOR 45 W	58	58	43/56	****	5	57X26X57	1	0,082
LABOR 60 W	58	58	58/84	****	9	57X26X57	1	0,082

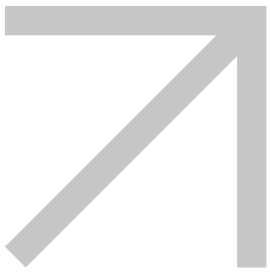

ARIA
UNIVERSAL
CONFERENZA
CONFERENZA PLASTICA + WOOD
CONFERENZA NET + ECO
LUNA
GIMMY & SOLE
VERA & ELENA
DIVANO MAX
DIVANO REX
DIVANO PARIS
DIVANO DUKE

STATE COMODI!
PERFECTLY SEATED!



C'è una poesia nei luoghi di passaggio,
che, come isole, ci accolgono nel nostro viaggiare.
Sono luoghi dove sfogliare un libro,
fantasticare, conversare con qualcuno
o semplicemente rilassarci e non fare nulla.
Abbiamo messo molta cura nel progettare
questa gamma di prodotti destinati alle reception
e sale d'attesa: li abbiamo voluti confortevoli,
ergonomici, capaci di farsi notare con eleganza e stile.
Ve li presentiamo con tutta la ricchezza dei materiali,
delle finiture e delle varianti cromatiche più versatili.

There is a poetry in transit places,
as islands, host us while we are travelling.
Places were mix in a book, daydream,
chat with someone or simply relaxing and doing anything.
We put a lot of passion to design this line
of products for reception and waiting room:
we wanted them to be comfortable, ergonomics,
able to stand out with elegance.
We present them with the full richness of their materials,
finishing and customizable chromatic variations.



CONFERENZA_ATTESA

CONFERENCE & WAITING

A R I A

CATAS

UNI EN 13761:2002
UNI EN 15373:2007
UNI EN 1728:2000
UNI EN 9083:1987
UNI EN 1022:005

P R O D U C T A N D D E S I G N

M A D E I N I T A L Y



ARIA_4G

84



ARIA



ARIA_CON
BRACCIOLI



ARIA_CON BRACCIOLI
E TAVOLETTA



ARIA_PANCA RIBALTABILE



ARIA_PANCA MOBILE



	A	H	H	H	kg		n	m ³
SEDIA	47	54	46	81	6	66X58X107	4	0,41
CON BRACCIOLI	66	54	46	81	7,5	66X58X107	4	0,41
CON BR E TAV	69	74	46	81	9	66X58X107	4	0,41

UNIVERSAL

CATAS

UNI EN 15373:2007
UNI EN 1728:2000
UNI EN 1022:005

PRODUCT AND DESIGN

MADE IN ITALY



UNIVERSAL NET_SLITTA



UNIVERSAL_SLITTA



UNIVERSAL NET_SLITTA



UNIVERSAL_4G



UNIVERSAL NET_SLITTA



UNIVERSAL_4G



UNIVERSAL NET_4G

	A	H	h	h	kg		n	m ³
4 GAMBE	51	55	46	80	7	66X58X107	4	0,41
4 GAMBE CON BR	60	55	46	80	8	66X58X107	4	0,41
SLITTA CON BR	53	54	46	80	9	66X58X107	4	0,41

C O N F E R E N Z A



P R O D U C T A N D D E S I G N

M A D E I N I T A L Y



CONFERENZA



88



CONFERENZA



CONFERENZA_CON BRACCIOLI



CONFERENZA_CON BRACCIOLI
E TAVOLETTA



CONFERENZA_PANCA 3 POSTI



CONFERENZA_CON BR



CONFERENZA_CON BR + TAV

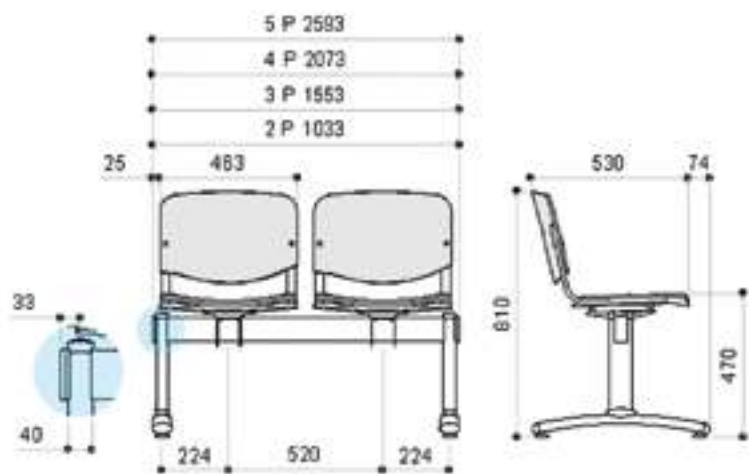

							n	m ³
SEDIA	53	59	45	84	6	66X58X107	4	0,41
CON BRACCIOLI	67	59	45	84	7,5	66X58X107	4	0,41
CON BR E TAV	71	74	45	84	9	66X58X107	4	0,41

CONFERENZA PL+W

PRODUCT AND DESIGN

MADE IN ITALY



CONFERENZA_PL

90



CONFERENZA_PL



CONFERENZA_WOOD



CONFERENZA_WOOD



CONFERENZA_PL

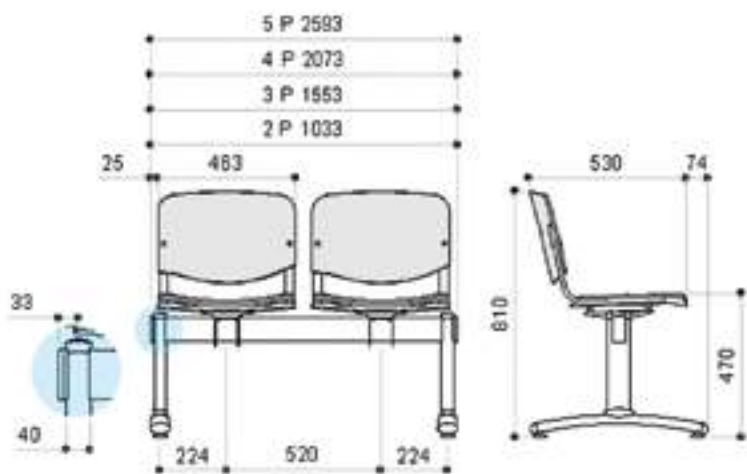

							n	m ³
SEDIA	47	54	46	81	6	66X58X107	4	0,41
CON BRACCIOLI	67	54	46	81	7,5	66X58X107	4	0,41
CON BR E TAV	71	74	46	81	9	66X58X107	4	0,41

CONFERENZA NET + ECO

PRODUCT AND DESIGN

MADE IN ITALY



CONFERENZA_NET



CONFERENZA_ECO



CONFERENZA_NET



CONFERENZA_ECO



CONFERENZA_ECO

							n	m ³
SEDIA	47	54	46	81	6	66X58X107	4	0,41
CON BRACCIOLI	67	54	46	81	7,5	66X58X107	4	0,41
CON BR E TAV	71	74	46	81	9	66X58X107	4	0,41

LUNA

PRODUCT AND DESIGN

MADE IN ITALY



LUNA



94



LUNA



LUNA_C/BR



LUNA_SW



LUNA_C/BR



LUNA_SW



LUNA_SW

	A	H	h	h	kg		n	m ³
SEDIA	57	56	46	82	5	66X58X107	4	0,41
CON BRACCIOLI	60	56	46	82	7	66X58X107	4	0,41
SWIVEL	58	58	43/56	95	7	61X61X36	1	0,13

GIMMY & SOLE

PRODUCT AND DESIGN

M A D E I N I T A L Y



GIMMY_4G

96



GIMMY_4G



GIMMY_SW



SOLE



GIMMY_SW



GIMMY_SW



SOLE_GIALLO



							n	m ³
GIMMY 4 G	63	53	46	81	7	71X66X55	4	0,26
GIMMY SW	58	58	43/56	95	9	61X61X36	1	0,13
SOLE	52	57	46	80	8	61X53X92	4	0,30

V E R A & E L E N A

P R O D U C T A N D D E S I G N

M A D E I N I T A L Y



VERA



98



VERA









VERA_SW



ELENA



ELENA

							n	m ³
VERA 4G	53	58	46	78	6	66X58X107	4	0,41
VERA SW	58	58	43/56	84	7	61X61X36	1	0,13
ELENA	53	57	46	79	4	58X52X106	4	0,32

M A X

P R O D U C T A N D D E S I G N

M A D E I N I T A L Y



100



MAX 1P



MAX 2P



MAX 3P

							n	m ³
1P	83	62	45	60	26	85X64X62	1	0,34
2P	125	62	45	60	30	127X64X62	1	0,51
3P	172	62	45	60	38	174X64X62	1	0,69

R E X

P R O D U C T A N D D E S I G N

M A D E I N I T A L Y



102



REX



REX_1P



REX_2P



REX_3P

							n	m ³
1P	60	60	46	73	30	62X62X75	1	0,29
2P	118	60	46	73	38	121X62X75	1	0,57
3P	173	60	46	73	44	175X62X75	1	0,82

P A R I S

P R O D U C T A N D D E S I G N

M A D E I N I T A L Y



PARIS

104



PARIS_1P



PARIS_2P



PARIS_3P

							n	m ³
1P	71	60	45	71	18	73X62X73	1	0,33
2P	125	60	45	71	25	127X62X73	1	0,58
3P	175	60	45	71	37	177X62X73	1	0,81

D U K E

P R O D U C T A N D D E S I G N

M A D E I N I T A L Y



106









DUKE



DUKE_1P



DUKE_2P

							n	m ³
1P	69	63	46	78	18	101X97X86	2	0,85
2P	124	63	46	78	27	101X97X86	1	0,85

CARTELLA COLORI_FABRICS AND COLORS

CAGLIARI CAT. D



C002 Rosso Red C006 Blu Blue C011 Nero Black C038 Grigio scuro Dark gray C013 Grigio chiaro Light gray C034 Verde Green

Composizione: 50% PES, 40% PAC, 10% fibre sintetiche - Martindale → **25.000 cicli** - Peso: **270 g/mq**
Colori Rosso, Blu e Nero di serie. Per altri colori, supplemento di prezzo.

Composition: 50% PES, 40% PAC, 10% synthetic fibers - Martindale → **25.000 cycles** - Weight: **270 g/mq**. Standard colors Red, Blue e Black.

BONDAI CAT. C



B411 Rosso Red B312 Arancio Orange B305 Oca Ocher B105 Avorio Ivory B878 Grigio Gray B748 Verde Green B671 Blu Blue B833 Nero Black

Composizione: Crepe 100% Poliestere - Martindale → **150.000 cicli** - Peso: **350 g/mtl**

Certificato Ignifugo: classe 1.IM - EN1021/1-2 cigarette - Crib 5 (BS 5852 part II) - BS 7176 Medium Hazard

Composition: Crepe 100% Polyester - Martindale → **100.000 cycles** - Weight: **350 g/mtl**

Fireproof certificate: EN1021/1-2 cigarette - Crib 5 (BS 5852 part II) - BS 7176 Medium Hazard

SILVIA CAT. C SIMILPELLE_LEATHERETTE



S001 Bianco White S002 Crema Cream S018 Nero Black S010 Rosso vivo Bright red S29 Blu avio Blue avio

Composizione: Avanti: 100% Poliuretano; Retro 65% PL-35% CO - Martindale → **50.000 cicli** - Peso: **540 g/mtl**

Composition: Front: 100% polyurethane; Back 65%PL-35% CO - Martindale → **50.000 cycles** - Weight: **540 g/mtl**

KINGFLEX TREVIRA CS CAT. B

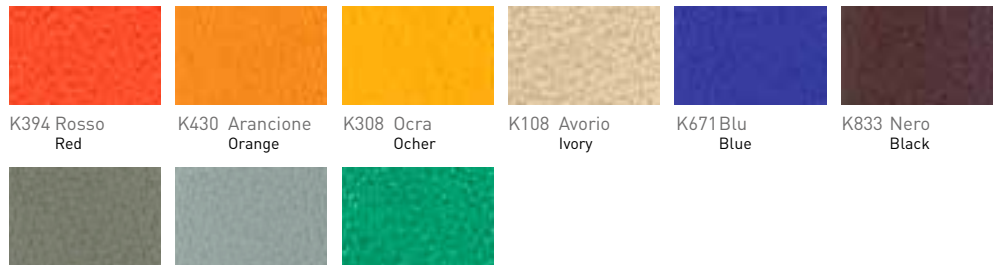

K394 Rosso Red K430 Arancione Orange K308 Oca Ocher K108 Avorio Ivory K671 Blu Blue K833 Nero Black
K807 Grigio scuro Dark Gray K814 Grigio chiaro Light Gray K777 Verde Green

Composizione: Jaquard sablé 100% poliestere Ignifugo TREVIRA CS - Martindale → **100.000 cicli** - Peso: **420 g/mtl**

Certificato Ignifugo: classe 1.IM - C1 (UNI 9174 - UNI 8456) - M1 (NF P 92501-7) - B1 (DIN 4102) - EN 1021-1 cigarette

Composition: Jaquard sablé 100% polyester fireproof TREVIRA CS - Martindale → **100.000 cycles** - Weight: **420 g/mtl**

Fireproof certificate: classe 1.IM - C1 (UNI 9174 - UNI 8456) - M1 (NF P 92501-7) - B1 (DIN 4102) - EN 1021-1 cigarette

SIRIA CAT. B SIMILPELLE IGNIFUGA



I001 Bianco White I002 Crema Cream I018 Nero Black I010 Rosso vivo Bright red I026 Blu Blue

Composizione: Avanti 93%PVC - 7% PU Retro 28% PL - Martindale ← **100.000 cicli** - Peso **812 g/mtl**

Certificato ignifugo Cl 1IM - BS5852:06 IS 0 e IS 1 ; Uso Navale FTP Code 2010 parte 8

Composition: Front: 93%PVC - 7% PU; Back 28% PL - Martindale ← **100.000cycles** - Weight: **812 g/mtl**

Fireproof certificate: Cl 1IM Italy - BS5852:06 IS 0 e IS 1 - Naval Use FTP Code 2010 parte 8

PELLE P1 SMERIGLIATO O CROSTINA _LEATHER P1 FIRST QUALITY AND P2 SECOND QUALITY

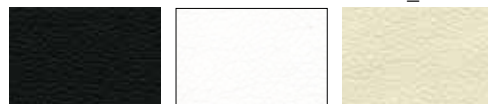

Nero Black Bianca White Avorio Ivory



TESSUTI CONFERENZA-ECO MISURINA 100% POLIESTERE_CONFERENZA-ECO FABRIC COLORS POLYESTER



128 BLU Blue 127 Rosso Red 121 Nero Black 123 Antracite Anthracite

COLORI TEKNIK T - C - PELLE O SIMILPELLE_LEATHER OR LEATHERETTE



Nero Black Rosso Red Blu Blue Bordeaux Burgundy Verde Green Grigio Grey Bianco White Avorio Ivory Marrone Brown

COLORI TEKNIK - R - RETE_MESH



Rosso Red Nero Black Grigio scuro Dark gray Grigio perla Pearl Grey Bordeaux Burgundy Bianco White

COLORI CONFERENZA PL_PLASTICS COLORS



Beige RAL 1001 Blu RAL 5003 Bordeaux RAL 3004 Giallo RAL 1016



Grigio RAL 7036 Nero RAL 9017 Verde RAL 6004

Nero e blu sono disponibili senza minimi di quantità. Altri colori disponibili per ordini di 60 sedie e multipli
Colori a richiesta: ordine minimo 500 sedie

Black and blue always available. For other colors, minimum order 60 chairs or multiples of 60.

COLORI SEDIA LUNA PL



Bianco White Bordeaux Burgundy Grigio Grey Verde Green Blu Blue Pesca Peach

COLORI GIMMY PL



Arancio Orange Verde Green Bianco White Rosso Red Nero Black Azzurro Light blue

COLORI SOLE PL



Blu Blue Giallo Yellow Rosso Red Grigio Grey Bordeaux Burgundy Verde Green Nero Black

COLORI GUM E VERA PL



COMPONENTI



PIEDINI_GLIDES
in PP stampato a iniezione, con perno in acciaio D11 ad innesto rapido
injection molded PP, with fast coupling steel pivot Ø 11



RUOTE NERE BLACK CASTORS
in nylon, D50 mm, perno D11 ad innesto rapido, libere o auto-frenanti
Ø 50 mm, fast coupling pivot Ø 11 free or Self-braking



RUOTE NERE GOMMATE
in nylon, D50 mm, perno D11 ad innesto rapido, libere o auto-frenanti
BLACK CASTOS FOR HARD FLOOR Ø 50 mm, fast coupling pivot Ø 11 free or Self-braking



RUOTE GRIGIE GOMMATE
in nylon, D50 mm, perno D11 ad innesto rapido, libere
GREY CASTOS FOR HARD FLOOR Ø 50 mm, fast coupling pivot Ø 11 free



B03 - B04 Base in nylon caricato 30% FV, cono centrale D50 con rastrematura anti-scivolamento della pompa, ruote perno D11, stesso design, diverse dimensioni: B03: D630 mm - B04: D700 mm
30% FV nylon base, Ø 50 central cone with taper anti-slipping of the lift., castors pivot Ø 11, same design, different dimensions



B20 - B21 - B22
Base in nylon caricato 30% FV, cono centrale D50, ruote perno D11, stesso design, diverse dimensioni: B20: D600 mm - B21: D645 mm - B22: D680 mm
30% FV nylon base, Ø 50 central cone, castors pivot Ø 11, same design, different dimensions



B23
Base piramidale in nylon caricato 30% FV, cono centrale D50 con anello in acciaio anti-scivolamento della pompa, ruote perno D11, unica dimensione D 710 mm
30% FV nylon pyramidal base, Ø 50 central cone with steel ring, castors pivot Ø 11, only Ø 710 mm



B36
Base in tubo acciaio 40x20 mm, cono centrale D50 ruote perno D11, unica dimensione D 630
40x20 mm steel tube base, Ø 50 central cone, castors pivot Ø 11, only Ø 630



B04
Base in alluminio lucidato, cono centrale D50, ruote perno D11, unica dimensione D700
Polished aluminum base, Ø 50 central cone, castors pivot Ø 11, only Ø 700



B23 ALL
Base in alluminio presso fuso e lucidato, cono centrale D50, ruote perno D11, unica dimensione D710
Die-cast and polished aluminum base, Ø 50 central cone, castors pivot Ø 11, unique dimension: Ø 710

ACCESSORI



BR0801
Bracciolo nylon nero, ambidestro, per sedie mod. Conferenza, Conferenza Plastica, Confer-Eco, Confer-Net, Confer-wood. Si montano sulla sedia tramite innersto a pressione.
Black nylon armrest couple, ambidextrous, for all Conferenza chairs models



BR10
Coppia braccioli destro e sinistro stampati in poliammide FV nero.
Black FV polyamide armrest.



BR08TAV
Bracciolo destro con tavoletta scrittoio nylon nera, per Conferenza, Conferenza-eco/plastic/wood/net. Lo snodo viene fornito già montato sulla tavoletta. Dim. tavoletta: 350 x 250 mm Spess. 20 mm
Black nylon writing table with right arm, for Conferenza, Conferenza-eco/plastic/wood/net, models. Shipped disassembled, with pivot included.



BR12
Coppia braccioli destro e sinistro stampati in poliammide FV nero.
Black FV polyamide armrest.



BR03
Coppia braccioli ambidestri, stampati in polipropilene nero
Black ambidextrous polypropylene armrest.



BR23
Coppia braccioli destro e sinistro stampati in poliammide FV nero pad in polipropilene.
Black FV polyamide armrest, polypropylene pad.



BR04
Coppia braccioli ambidestri, stampati in polipropilene nero
Black ambidextrous polypropylene armrest.



BR27
Coppia braccioli destro e sinistro stampati in poliammide FV nero, pad in polipropilene, neri.
Black FV polyamide armrest, polypropylene pad.



PP05 – PP05TRS

Meccanismi sincro, con regolazione di tensione, sicurezza anti-shock, con 4 blocchi .

PP05: meccanismo sincro

PP05TRS: sincro con traslatore ROS integrato (ROS=Regolazione Orizzontale del Sedile)

Syncro mechanism, with tension adjustment, safety anti-shock, 4-position block

PP05: syncro mechanism

PP05TRS: syncro with integrated R.O.S. (Horizontal Seat Adjustment)



PP09 – PP09TRS

Meccanismi sincro, con regolazione di tensione laterale, sicurezza anti-shock, con 5 blocchi.

PP09: meccanismo sincro

PP09TRS: sincro con traslatore ROS integrato (ROS=Regolazione Orizzontale del Sedile)

Syncro mechanism, with lateral tension adjustment, safety anti-shock, 5-position block

PP09: syncro mechanism

PP09TRS: syncro with integrated R.O.S. (Horizontal Seat Adjustment)



PP13 – PP16

Meccanismi oscillanti e tilting per poltrone direzionali.

PP13: oscillante 1 blocco in posizione operativa

PP16: tilting a fulcro avanzato, 5 blocchi

Tilting mechanisms for managerial armchairs.

PP13: centered fulcrum tilting, 1-block in operating position

PP16: advanced fulcrum tilting, 5-block



SUPPORTO FISSO

Supporto schienale per sedie con schienale fisso o regolabile solo in altezza o con movimento sincro.

Regolazione in H manuale o up-down, a scelta

Back support for fix or only-height adjustable back seats.

Manual or Up-Down adjustment.



CONTATTO PERMANENTE MANUALE

Contatto permanente, blocco manuale con manopola. La regolazione in altezza dello schienale può essere manuale o up-down.

Permanent contact, manual block with knob. Manual or Up-Down height adjustment.



CONTATTO PERMANENTE A LEVA

Contatto permanente con pratico blocco a leva, che garantisce una maggior semplicità di utilizzo ed una maggior tenuta. La regolazione in altezza è solo up-down.

Permanent contact with comfortable lever lock which guarantees an easier use and major holding. Up-Down height adjustment only.



R501

Anello poggipiedi regolabile in altezza, per sedie disegnatore. Anello in tubo acciaio cromato D18 e

Razze in nylon caricato FV. Completo di volantino di bloccaggio. Dimensioni: D 450 mm

Height adjustable footrest ring, for technical chairs. Ring in chromed steel Ø 18 tube and FV nylon strokes. Block handwheel included. Dimensions: Ø 450 mm



P06– P01 – P09 – P02 – P04

Colonne a gas di varie dimensioni, con tubo verniciato nero o cromato.

P06: colonna h375–corsa260–tubo per Disegnatore

P01: colonna h240–corsa130–tubo D50 Dattilo

P09: colonna h230–corsa115 per basi B23

P02: colonna h205–corsa100 per Direzionali

P04: colonna h215–corsa 120 CROMATA

Gas-lift of different dimensions, with varnished black tube or chrome.

P06: height column 375–lift260–technical chairs tube black or chrome

P01: height column 240–lift130–typist chair Ø50 tube, only black

P09: height column 230–lift115 for B23 bases only black

P02: height column 205–lift100 for managerial chair only black

P04: height column 215–lift120 for managerial chair only chrome



BR18

Coppia braccioli destro e sinistro stampati in poliammide FV nero. Pad in poliuretano integrale morbido, neri.

Black FV polyamide armrest, soft PU pad.



BR19

Coppia braccioli destro e sinistro regolabili in altezza, supporto nero o cromato, stampato in poliammide FV. Pad nero stampato in polipropilene.

Height adjustment armrest couple, black or chromed FV polyamide support. Black polypropylene pad black.



BR16

Coppia braccioli ambidestri in acciaio cromato, pad in polipropilene.

Chromed steel armrest couple, polypropylene pad.



BR28

Coppia braccioli destro e sinistro regolabili in altezza, supporto nero o cromato, stampato in poliammide FV. Pad nero stampato in polipropilene.

Height adjustment armrest couple, black or chromed FV polyamide support. Black polypropylene pad black.



BR11

Coppia braccioli destro e sinistro regolabili in altezza, supporto nero o cromato, stampato in poliammide FV. Pad nero stampato in polipropilene.

Height adjustment armrest couple, black or chromed FV polyamide support. Black polypropylene pad black.



BR29

Coppia braccioli destro e sinistro regolabili in altezza, supporto nero o cromato, stampato in poliammide FV. Pad nero in poliuretano integrale morbido.

Height adjustment armrest couple, black or chromed FV polyamide support. Soft black PU pad.



BR13

Coppia braccioli destro e sinistro regolabili in altezza, supporto nero o cromato, stampato in poliammide FV. Pad nero stampato in polipropilene.

Height adjustment armrest couple, black or chromed FV polyamide support. Black polypropylene pad black.



BR30

Coppia braccioli destro e sinistro regolabili in altezza, orientabili, supporto in acciaio cromato, staffa in acciaio verniciato nero. Pad nero stampato in polipropilene.

Height adjustment armrest couple, swivel, chromed steel support, varnished black steel clamp. Black polypropylene pad black.



BR26

Coppia braccioli destro e sinistro regolabili in altezza, supporto nero o cromato, stampato in poliammide FV. Pad nero stampato in polipropilene.

Height adjustment armrest couple, black or chromed FV polyamide support. Black polypropylene pad black.



BR31

Coppia braccioli destro e sinistro regolabili in altezza, orientabili, supporto in acciaio cromato, staffa in acciaio verniciato nero. Pad nero stampato in polipropilene.

Height adjustment armrest couple, swivel, chromed steel support, varnished black steel clamp. Black polypropylene pad black.

E R G O N O M I A

Lo studio dell'ergonomia, applicata alle sedie per ufficio, sviluppa la costante ricerca della flessibilità d'utilizzo delle stesse e della loro capacità di adattarsi sempre al meglio a strutture corporee molto diverse tra loro per conformazione, struttura, peso, statura, postura operativa. Di seguito indichiamo le regolazioni che potrete trovare, di volta in volta, sulle nostre sedie. Tutte le sedie hanno il sedile regolabile in altezza tramite pompa a gas.

Ergonomics study applied on office chairs develops a constant research on flexibility of use and capacity of great adaptation on different human body structures, which can vary according to body shape, structure, weight, height, and task posture. In the following section, we list the types of adjustments you might find in our chairs. All chairs have height adjustable seat with gas-lift.



- **FISSO** Schienale e sedile regolabili solamente in altezza. Abbiamo scelto di utilizzarlo solamente a richiesta, in quanto ergonomicamente inadatto.
FIX Height-only adjustable back and seat chair. We have chosen to adopt it only on demand, as it is not ergonomically suitable.



- **CONTATTO PERMANENTE** Schienale regolabile in inclinazione, si blocca in qualsiasi posizione o rimane libero di oscillare. Regolazione in altezza manuale o Up/Down.
PERMANENT CONTACT Tilting adjustable back. It can both block in any position and be free of swinging. Manual or Up-Down height adjustment.



- **ASYNCRO** Schienale e sedile regolabili in inclinazione, indipendenti tra loro. Regolazione manuale dell'altezza dello schienale. Disponibile solo a richiesta.
ASYNCRO Tilting adjustable back and seat-independent from each other. Height back with manual adjustment. Available only on demand.



- **SYNCRO** Schienale e sedile regolabili in inclinazione, sincronizzati tra loro. Regolazione dell'altezza dello schienale Up-Down. Sempre dotato di Regolatore di tensione per adattare la forza dell'oscillazione al peso corporeo dell'utente.
SYNCRO Tilting adjustable back and seat-synchronized with each other. Height back with Up-Down adjustment. Tension adjuster always included, in order to adapt the swinging force to the body weight.



- **R.O.S.** Acronimo di Regolazione Orizzontale del Sedile. Regola la profondità del sedile e la adatta alla lunghezza del femore dell'utente.
R.O.S. Acronym for Horizontal Seat Adjustment Range (in Italian Regolazione Orizzontale del Sedile). It adjusts and adapts seat depth to user's femur length.



- **BRACCIOLI REGOLABILI** I braccioli possono avere svariate regolazioni, in altezza, in larghezza, in profondità e possono avere l'appoggio orientabile.
ADJUSTABLE ARMRESTS Armrests can be adjusted in different ways: in height, in width, in depth. They can have also adjustable support.



- **TILTING** Meccanismo basculante per sedie monoscaocca, è caratterizzato dal punto di rotazione molto avanzato che permette una oscillazione estremamente gradevole. Sempre dotato di Regolazione di tensione e bloccabile in più posizioni.
TILTING The tilting mechanism for monocoque chairs is characterized by an innovative rotation point which allows a pleasant swinging. Tension adjuster always included and can be blocked in several positions.



- **OSCILLANTE** Meccanismo basculante per sedie monoscaocca, è caratterizzato dal punto di rotazione centrato sul pistone a gas. Più economico del precedente, ha una oscillazione meno gradevole. Sempre dotato di Regolazione di tensione, è bloccabile in posizione operativa.
OSCILLATING The tilting mechanism for monocoque chairs is characterized by a gas-lift centered rotation point. It is cheaper than the previous one and its swinging is less pleasant. Tension adjuster always included and can be blocked in task position.



- **UP-DOWN** Letteralmente "su-giù"; è un sistema di regolazione in altezza dello schienale che non necessita di viti di bloccaggio. Permette di alzare, a scatti, lo schienale fino alla posizione desiderata; per abbassarlo, si va a fine corsa in alto e scende automaticamente.
UP-DOWN It is a height adjustment system that does not need fixing screws. It is used both in some height-adjustable armrests and in backs. It allows to lift up till the sought position stepwise; in order to low down, go to end top and it goes down automatically.



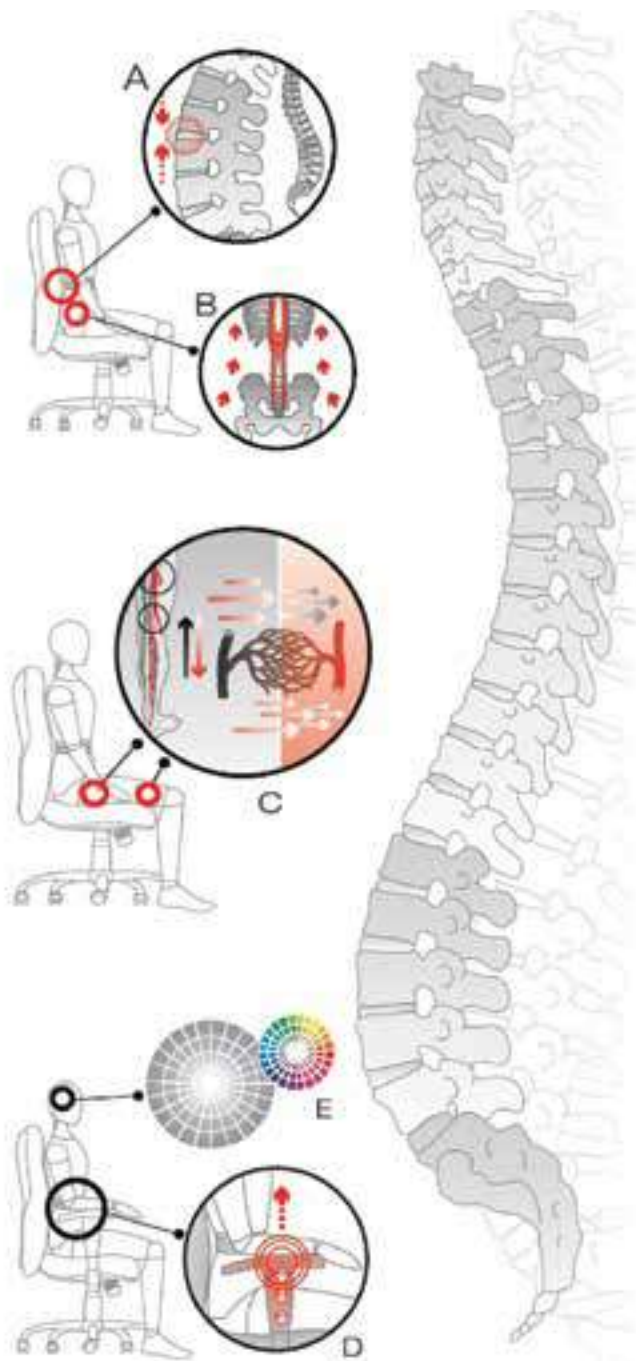

Siamo tutti fisicamente diversi.

Conoscere il prodotto permette di fare la scelta migliore.

Scegliere la sedia giusta:

- salvaguarda la salute
- affatica di meno
- aumenta la produttività

Non dimenticare che:

- Non sempre spendendo tanto si ha il prodotto migliore!
- Non sempre spendendo poco si risparmia!

We are physically different from each other.

If you know the product, you can make the best choice.

Choosing the right chair means:

- good health
- less stress
- higher working performance

Remember that:

If you have a high expenditure, it doesn't always mean that you purchase the best product. If you spend little money, it doesn't always mean that you save money.

La necessità di ragionare su come progettiamo e costruiamo i complementi per ufficio non nasce solo da obiettivi di migliore funzionalità e più facile operatività ma prima ancora da ragioni di salute.

Gli studi sul nostro rapporto con il lavoro confermano che circa il 65% dei lavoratori non si siede nel modo corretto, talvolta per cattive abitudini posturali e altre volte perchè la sedia non è adatta.

Se pensiamo che, durante la nostra vita scolastica e professionale, trascorriamo in media 80.000 ore seduti, possiamo intuire quanto è importante disporre di un'ottima sedia!

Se non abbiamo una sedia adeguata, non solo stiamo scomodi, ma possiamo sviluppare, nel tempo, gravi fastidi e cattive abitudini che possono diventare vere e proprie patologie.

Una postura sbagliata, infatti, può compromettere anche la funzione di altri gruppi muscolari, portando, per esempio, a sviluppare fastidiose contratture muscolari nell'area della nuca e delle spalle.

Una buona seduta per ufficio deve favorire una postura dinamica, che permetta di alternare rilassamento e tensione dei diversi gruppi muscolari.

La sedia può e deve permettere questo dinamismo, assecondando con la sua elasticità i movimenti della persona.

Le sedute che progettiamo e costruiamo facilitano una postura corretta, equilibrata e dinamica.

Il corpo viene facilitato nell'assumere la posizione più favorevole, riducendo il carico sulla colonna vertebrale.

Non solo si lavora più concentrati, ma si prevengono anche patologie croniche a carico dell'area cervicale e dorsale.

Scegliere la sedia giusta per il proprio tipo di attività è, quindi, fondamentale.

Anche sapersi sedere correttamente è molto importante.

Ricordate sempre che:

- è bene utilizzare tutta la profondità del sedile
- i gomiti devono poggiare comodamente sulla superficie della scrivania, così i muscoli delle spalle sono più rilassati
- l'angolo formato da busto e cosce normalmente dovrebbe essere maggiore di 90°/95°.

In questo modo, l'inclinazione del bacino che ne consegue stimola la parte superiore del corpo ad assumere una postura eretta.

The need to think about how we design and build up our chairs it doesn't come only from the purpose of increase functionality and an easier operability but mostly by reasons of health.

Studies on our relationship with work in the office confirm that about 65% of workers do not sit properly, sometimes for bad postural habits or because the chair is not suitable.

If we consider that during our school and professional life we spend an average of 80,000 hours seated, we can imagine how is important to have a good chair!

If we do not have an appropriate chair, we are not only uncomfortable, but over time we can also develop serious hassles and bad habits that can become real diseases.

An incorrect posture can also impair the function of other muscle groups, leading for example to develop uncomfortable muscular contractures on neck and shoulders area.

A good office chair must facilitate a dynamic posture, which allows to alternate relax and tension of different muscle groups.

The chair can and have to allow this dynamism by favoring body movements with elasticity.

The chairs that we design and build facilitate proper posture, balanced and dynamic.

The body is facilitated in taking the most favorable position, reducing the weight on the spinal column.

Not only this allows to work more concentrated, but also prevent chronic pathologies of the neck and back.

Choosing the right chair for your type of work is, therefore, crucial.

Also know how sit down correctly is very important.

Always remember:

- it is good to use the whole seat depth
- elbows should comfortably rest on the surface of the desk, so shoulder muscles are more relaxed
- the angle from bust and thighs should normally be larger than 90 ° / 95 °.

In this way, the inclination of the pelvis that comes with it stimulates the upper part of the body to assume an upright posture.

DOVE NASCE CKS_WHERE IS CKS

P R O D U C T A N D D E S I G N

M A D E I N I T A L Y

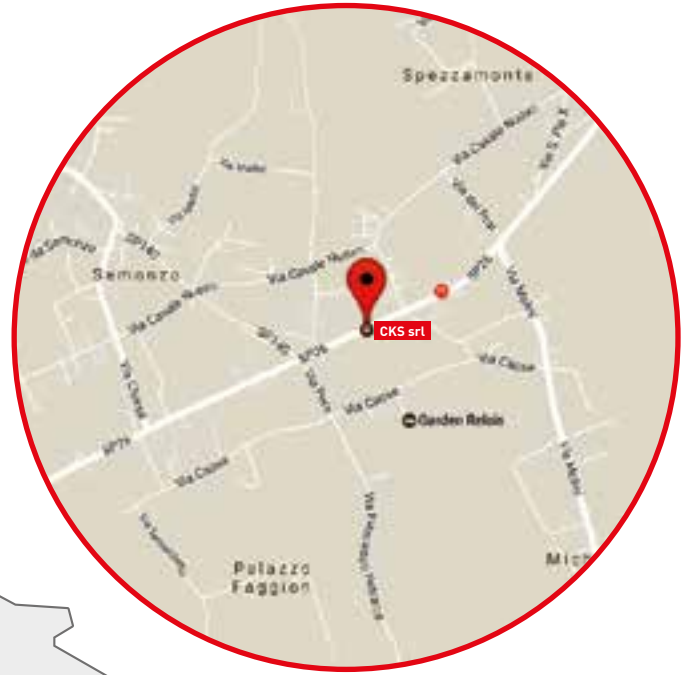

sede produttiva principale_headquarters



sala esposizione_show room



stampaggio componenti_injection molding components



sala prove_testing room



tappezzeria_upholstery



stampaggio componenti_injection molding components



stampaggio componenti_injection molding components



magazzino componenti_stock components



magazzino prodotti finiti_stock finished products



CONDIZIONI DI VENDITA RISERVATE SALES CONDITIONS

SCONTO _DISCOUNT _____ %

TRASPORTO _TRANSPORT CONDITIONS _____

PAGAMENTO _PAYMENT _____

VALIDITA' _VALID UNTIL _____

REFERENTE

SIG.RA / SIG. _MS / MR _____

TELEFONO _PHONE _____

CELLULARE _MOB _____

E-MAIL _____



CKS s.r.l.
100% made in Italy

RICERCA ALFABETICA_ ALPHABETIC INDEX

	PAG. CATALOGO	PAG. LISTINO
ARIA	84	37-38
ARIEL	60	28
ATENA	36	18
CALIPSO	34	17
COMFORT	56	27
CONFERENZA	88	40-41
CONFERENZA NET + ECO	92	40-41
CONFERENZA PLASTICA + WOOD	90	40-41
DAFNE	12	6-7
DIAMOND CR	8	4
DIAMOND	10	5
DISEGNATORE	76	35
DUKE	106	45
DRIADE	44	21
EASY CHAIR	46	22
ELENA	98	43
ERGOVAR	72	34
FANTAIL	62	29
FUTURA	16	9
GIMMY	96	42
GOLF	52	25
HERA	54	26
IRIS	20	11
LABOR PU	78	36
LABOR WOOD	80	36
LUNA	94	42
LUXOR	30	14
MAX	100	44
MIRAGE	64	30
NUVOLA	66	31
OLIMPIA	42	20
ORION	50	24
OXFORD	14	8
PARIS	104	45
PRESTIGE	22	12
REGAL	68	32
REX	102	44
SILLA	36	18
SOFIA	70	33
SOLE	96	42
TALIA	40	19
TAYLOR	48	23
TEKNIK-C	24	13
TEKNIK-R	28	13
TEKNIK-T	26	13
UNIVERSAL	86	39
URANIA	18	10
VENUS 2	32	15-16
VERA	98	43
CARTELLA COLORI	108	51-53
COMPONENTI E ACCESSORI	110	47-50
ERGONOMIA	112	3

CKS s.r.l.
Via Molinetto, 99
31030 Borso del Grappa
(TV) - ITALIA
Tel. +39 0423 910028
Fax +39 0423 910144
r.renzo@ckssrl.com
www.seditaly.it